



# DYNAMAX



# DIALOGUE



**Coach 12 Volt System Shutdown**  
**Ford E-series and F-series**  
**Isata Touring Sedan and DynaSport**

1. Locate inverter remote panel and disable inverter (XM1000) or inverter function (Prosine/RS2000).
2. Locate Intellitec Battery Disconnect panel and select "Store" mode. (Usually by the front door)

The above two steps remove the majority of the electrical load and should suffice for short term storage. For long term storage of more than 1 week, we recommended you take these additional steps:

3. Locate the L.P. Leak Detector and switch "off". Note, inverter electronics are always connected, but now are consuming minimum power.
4. Fully charge the battery banks and then remove the negative cable(s) from the house batteries. This will completely power down the house side of the unit. Note, except for AGS and inverter settings, all memory settings will be lost.

If you are using shore power during long term storage, shut disconnects off as above, leave negative cable(s) attached, disable the inverter and enable the charger.

**Check the unit and battery condition monthly.**

It should be noted that, even when the vehicle is not in use, electrical draw on the batteries continues. This parasitic draw may not be large but over time it will eventually draw the batteries down. It should also be noted that a physically dirty battery can have a parasitic draw due to electron flow across the dirt, dust and grime on the top of the battery.

There are two steps that can be taken to negate the effects of parasitic draw during periods of non use:

1. Check and charge the batteries once a month.
2. Disconnect the negative cable(s) from the batteries

## Coach 12 Volt System Shutdown

### All Freightliner Chassis DynaQuest and Grand Sport

1. Locate inverter remote panel and disable inverter function.
2. Locate Intellitec Battery Disconnect panel and select "Store" mode.

The above two steps remove the majority of the electrical load and should suffice for short term storage. For long term storage of more than 1 week, we recommended you take these additional steps:

3. Locate Intellitec Battery Disconnect panel and select "Store" mode.
4. Locate the battery negative switch under the driver seat in the cockpit, and turn it to the "off" position.
5. (DynaQuest) Fully charge the battery banks and then remove the negative cables from the house batteries. This will completely power down the unit. Note, except for AGS and inverter settings, all memory settings will be lost.
6. (Grand Sport) Fully charge the battery bank and then locate the battery negative disconnect switch in the battery control compartment and turn it to the "off" position. Note, except for AGS and inverter settings, all memory settings will be lost.

If you are using shore power during long term storage, leave disconnects on or "In-Use, disable the inverter and enable the charger. Check the unit and battery condition monthly.

It should be noted that, even when the vehicle is not in use, electrical draw on the batteries continues. This parasitic draw may not be large but over time it will eventually draw the batteries down. It should also be noted that a physically dirty battery can have a parasitic draw due to electron flow across the dirt, dust and grime on the top of the battery.

There are two steps that can be taken to negate the effects of parasitic draw during periods of non use:

1. Check and charge the batteries once a month.
2. Disconnect the negative cable(s) from the batteries

**XL MODELS**  
**Battery disconnects & fuses**

The main battery disconnect for the XL models is located on the drivers side first compartment, mounted to the rear wall.

Enable this to power the interior disconnect switch located in the tower cabinet behind the drivers seat.

Enabling the interior disconnect switch supplies power to the coach and all multi-plex systems.

**NOTE:** This switch must be turned on to use the optional Power Cord Reel.

**MULTIPLEX FUSE LOCATIONS**

- 38XL** - At the floor under refrigerator
- 36XL** - Under rear dinette
- 34XL** - Under rear dinette

**ST & XL MODELS**  
**AGS System w/RV comfort thermostat and  
RS-2000/RS-3000 inverter**

**Using the Xantrex panel, select the Auto Gen start mode (this will bring up a menu). Scroll down to AGS mode.**

**Using arrow keys, set to Automatic.**

**Continue to scroll down until you see the ENABLE TEMP 1 and ENABLE TEMP 2 settings.**

**Both of these may be turned to the ON position.**

**Exit the menu.**

**Using the thermostat, select the desired function:  
Ex: Electric heat pumps, air conditioning, etc...**

**Enable only 1 zone to start the generator.**

**Starting both zones simultaneously will draw too much power initially.**

**Once the generator has started, and the first AC is working, the other may be turned on.**

**This situation may be avoided by using different temperature settings for each zone.**

## Inverter Function

Most of the components in a Motorhome run off 12V power. The exceptions generally are the microwave, air conditioners, TV's and audio/visual equipment. The inverter allows you to run these components without being hooked up to shore power or running your generator. They work by producing a 60 hertz sine wave able to safely power these 110V appliances.

Using the inverter can be a very power intensive process and should be used with discretion. Whenever the inverter is on or enabled, it is drawing power from the batteries. As a general rule, it is recommended that the inverter be disabled, unless needed and the charger always enabled. Under these settings the batteries are always being charged while driving, using shore power or running the generator.

## Xantrex 1000 Watt

The XM Series Inverter is a quality inverter designed for recreational vehicle (RV) electrical systems that have a battery charger or generator already installed.

- The XM Series Inverter provides up to up to 1000 watts (XM 1000) of continuous modified sine wave power from a battery bank. It is designed to handle loads such as TVs and audio/visual components.
- A built-in 15 A supplementary circuit breaker protects the XM Series Inverter from overload.
- The cooling fan in the XM Series Inverter is both load activated and thermally activated. The fan turns off automatically after the inverter has cooled or the load has decreased.

1. **Locate inverter panel**
2. **Enable inverter by pushing the green button**
3. **Not recommended for long term use without charging batteries by either plugging in the unit with the shoreline, starting the generator or running the chassis motor.**
4. **This inverter will only power the front end of the coach (TV, satellite and sound system)**
5. **Read the Operation Manual to familiarize you with the main performance, safety and protection features of this component.**

## **Xantrex 2000 & 3000 Watt**

The RS2000/RS3000 Sine Wave Inverter/Charger is a convenient combination of an inverter, multistage battery charger, and transfer switch in one electronic device.

- As an inverter, the RS2000/RS3000 provides sine wave power for your microwave, entertainment system, computer, and other loads. This power is identical to the AC source provided from the utility grid (Power Company). Some of the benefits of sine wave power include consistent cooking in your microwave, handling of sensitive loads such as your TV set, dimmer switches, and appliances with speed controls.
- The RS2000 100 amp and RS3000 150 amp power-factor corrected chargers, quickly and efficiently recharge your batteries.
- The built-in transfer switch automatically transfers between inverter power and incoming qualified AC power.

### **Locate Xantrex panel (Tower cabinet behind Drivers' seat)**

1. **Push exit button until the selected device menu appears.**
2. **RS 2000/RS3000 should be highlighted**
3. **Push enter**
4. **Scroll down with the arrow key until Inverter is highlighted**
5. **Push enter. This will highlight the enable-disable function**
6. **Use the arrow key to change the menu to enable**
7. **Push enter**
8. **Inverter is enabled**  
**NOTE: Not recommended for long term use without charging batteries, either plug coach in with shore line, starting the generator or running chassis engine.**
9. **This inverter will power all the receptacles and all the front end electronics (TV-satellite, and sound system) plus the microwave.**
10. **On an all electric unit (e.g.-Hydro Hot system), the refrigerator will also be on the inverter.**
11. **Read the Operation Manual to familiarize you with the main performance, safety and protection features of this component.**
12. **NOTE: Do not push the red button on the system panel. Doing so can throw the system into a “coma” or “sleep mode”. Authorized service personnel use only.**
13. **NOTE: Resetting to Default Settings on system panel defaults to OEM or factory settings.**
14. **NOTE: Resetting on the inverter face panel defaults to User Setting**

## XANTREX INVERTER QUICK TROUBLESHOOTING

Your inverter system has been specified and tested to function in your installation. If you feel your inverter is not functioning properly, please check the following before contacting the manufacturer.

1. Is the inverter enabled?
2. Is the inverter in “Search Mode”?
3. Is the inverter in standby?

Solutions for each possibility are below (Owner’s manual page# or reference in parenthesis):

System Status			
Battery	12.8V	-3A	N/A
BatLev			Invert
Load	120V	0A	0A
AC In	0V	0A	0A
▼ menu	▼ DsInv	▼ DsChg	
Chr▼			

1. What is the inverter status?

- a. Qualifying AC

- i. This means that the inverter is disabled.
- ii. Please enable the inverter (Figure13 Page 23).

Inverter Status

- b. Load Sense

- i. This means that “Search Mode” has been enabled on the inverter.
- ii. Please disable Search Mode (Page 34-35).

- c. InvtrStandby

- i. This means that the inverter has been put in “Standby” mode.
- ii. This is usually done for safety; ensure that the environment is safe.
- iii. Put inverter in operating mode by holding the red STBY/ON button for three seconds.

- d. Invert

- i. This means the inverter is actively inverting.
- ii. Look at the “Load” line which should read inverter voltage and amperage.
- iii. If AC is still not available, check breakers/wiring.

- e. Bulk/Absorption/Float

- i. This means the unit is charging and should be passing AC through from shore or Generator.
- ii. Check AC in voltage and amperage. Compare to Load voltage and amperage.
- iii. If AC is still not available, check breakers/wiring.

For all other questions, please refer to the Troubleshooting chapter of the Owner’s manual on page 65.



## HOW TO USE THE XANTREX SOFT-KEYS

Your inverter system has been specified and tested to function in your installation. It is widely configurable requiring knowledge on the menu items available. However, the most common functions are available from the main screen. Instructions for these common functions are below.

1. Understanding the soft-keys
2. Turn the inverter/charger on/off
3. Program your AC input
4. Set your Automatic Generator Start

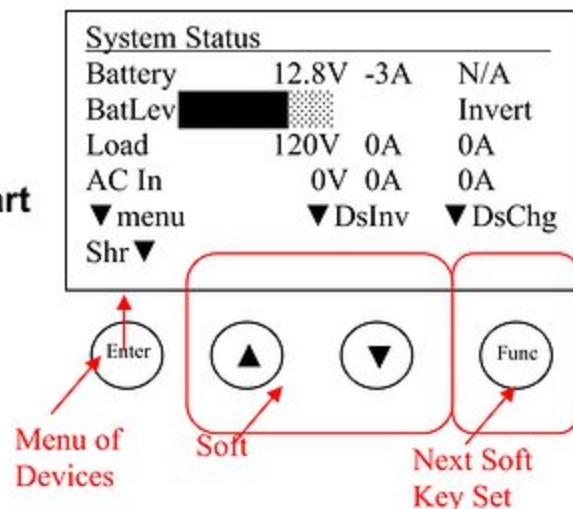

1. Understanding the soft-keys
  - a. The Menu Button is not involved in the soft-keys. It simply progresses the whole screen to the menu of connected devices on the network.
  - b. The Soft Keys are the ▲ and ▼ buttons in the normal menus, but from the main screen, they function according to the text on the screen directly above the keys.
  - c. The Func key changes the Soft Key Set above the ▲ and ▼ buttons depending on the connected devices on the network.1
  - d. The text above the Func, ▲, and ▼ buttons quickly show the setting of that value, or the command you can give.
    - i. For example, if the text above the ▲ button says "DsInv" then pushing the button sends a "Disable Inverter" command
    - ii. Likewise, if the text above the Func button is "Shr", then pushing the Func button sets the value of Power Share to what is showing after the change.

**2. Turn the inverter/charger on/off (this is a “Command” where the displayed command is what will be broadcast to all devices when the button is pushed).**

- a. Rotate through the Soft-Keys until “Home” is displayed above the Func button, then push once more to access the Inverter Soft Keys.**
- b. If the inverter is enabled, “Dslnv” will be displayed above the ▲ button.**
  - i. Push the ▲ button to disable.**
- c. If the inverter is disabled, “Enlnv” will be displayed above the ▲ button.**
  - i. Push the ▲ button to enable.**

**3. Program your AC input (this is a “Setting” where the displayed value is the current setting)**

**Note: AC input settings give the charger the ability to de-rate itself based on amperage draw of the charger AND the downstream loads. The charger will attempt to keep the total draw below the setting displayed. Unless the Sequence Energy Management System is utilized, the charger cannot de-rate based on loads not passed through (upstream of) the inverter, or if the total downstream load is above the setting.**

- a. Rotate through the Soft-Keys until “Shr” is displayed above the Func button, then push once more to access the Power Share Soft Keys.**
- b. Displayed will be PSxxA (where XX is the amperage allowed for Power Share)**
  - i. Push the ▲ or ▼ buttons to set the value desired setting.**
  - ii. When you stop pushing buttons, the value will be set within 2 seconds.**

5. **Set your Automatic Generator Start (this is a “Setting” where the displayed value is the current setting)**
  - c. **Rotate through the soft keys until “AGS” is displayed above the Func button, then push once more to access the Automatic Generator Start Soft Keys.**
  - d. **Displayed will be the current setting of the AGS Module**
    - i. **Push the ▲ or ▼ buttons to set the value desired setting.**
    - ii. **When you stop pushing buttons, the value will be set within 2 seconds.**
    - iii. **M\_Off means the system will manually turn off the generator.**
    - iv. **M\_On means the system will manually turn on the generator.**
    - v. **Auto means the system will begin monitoring for auto start/stop triggers.**

## LEVELING JACKS

**MANUAL – Turn on ignition – set park brake**

- 1. Locate air dump for DynaRide  
Ford E-series – center console switch panel  
Ford F-series – lower center on dash, switch number 3  
Freightliner M2 – on the HWH jack panel in tower cabinet**
- 2. Dump air bags using switch.  
It is NOT recommended to dump the air bags fully, leave some air in them**
- 3. Using the leveling jack control pad, push the arrows on the controller in the direction you wish the chassis to move ^ = Jacks go down**
- 4. When level, all the yellow lights on the panel will disappear. Turn off the panel and the ignition.**
- 5. When retracting jacks, turn on the ignition. Use the opposite arrow keys to slowly lower the chassis. This will allow the air bags to regain pressure as the unit lowers. When the bags are full, push the STORE button on the control panel. This will raise the jacks into travel mode.**
- 6. Make sure air bags are fully inflated before driving.**

## LEVELING JACKS

### **AUTOMATIC**

**Turn on ignition  
Set Park Brake**

- 1. Locate HWH control panel inside the tower cabinet behind the driver seat.**
- 2. Push the auto level button. This will automatically dump the air bags. Then level the coach.  
Turn off key**
- 3. When retracting Jacks  
Turn on key  
Hit auto store. Jacks will retract. When fully retracted, the panel will light up the travel mode indicator.**
- 4. Remember to start the chassis engine and allow the air bags to air up fully before driving.**

## **COMFORT CONTROL THERMOSTATE (ALL UNITS)**

- 1. Turn on the thermostat with the switch located on the bottom**
- 2. Use the zone button to highlight the desired zone (blinking)**
- 3. Use the mode button to select the desired function**

## **HYDRO HOT SYSTEMS**

- 1. Enable Hydro-hot system by turning on desired function (e.g. Electric, Diesel or Engine Pre-heat)**
- 2. Allow ample time for unit to heat, approximately 20 minutes.**
- 3. Hot water for lavs will be available in a shorter time period – approximately 5 minutes.**
- 4. Use comfort control panel to select furnace for heat, (above directions).**

## FRONT TV'S AND BOSE SYSTEM

Air channels and satellite use TV switch on Bose remote.

DVD function: Push DVD on Bose remote.

Use the TV/Video selector on TV remote to find the DVD input (usually video #1).

## REAR TV'S & BOSE ZONE 2

Air channels and satellite use aux switch on Bose remote.

DVD Function: Push DVD on Bose remote, use the TV / Video selector on the TV remote to find the DVD input (usually video #1).

The video selector switch box is used to change from Air channels to satellite (Aux) to Park cable (VCR) located under the front TV inside the cabinet.

Due to vendor changes, the TV brands may change, but the operation is basically the same for all of our units. Special order units will have a custom made sheet for the operation of all audio-video components.

## BOSE SYSTEMS REMOTES

<b>Zone 1</b>	<b>Zone 2</b>
<b>TV – Air &amp; Sat channels</b>	<b>TV – not used</b>
<b>CD – Audio CD</b>	<b>CD – Audio CD's</b>
<b>DVD – DVD Video</b>	<b>DVD – DVD video</b>
<b>AUX – not used</b>	<b>AUX – Air &amp; Sat. channels</b>
<b>SAT. – not used</b>	<b>SAT. – not used</b>

**ST & XL MODELS**  
**KENWOOD DDX-6019 Monitor w/DVD**

Using the V-select button on the stereo face, cycle through until the desired mode is achieved.

For using rear camera mode in travel, locate the lighted option switch and turn it on.

Cycle through the modes with the V-select button until back-up cam appears.

Units with the optional side cameras will have two option switches. The button on the right will cycle through the cameras manually.

To use the back-up camera normally (in reverse) disable the left switch.

**FORD E-450**  
**DASH RADIO**

Units are equipped with a Jensen flip out screen dash stereo.

To use the camera function, simply push the button labeled camera on the screen face.

The optional navigation feature is used by pushing the nav button on the stereo face.

You must use the supplied remote control to use the navigation system. It is not a touch screen.

Also, make sure that the navigation programming card (50 memory card) is installed into the navigation unit above the drivers' seat.

Follow onscreen instructions.



## KINGDOM SATELLITE SYSTEM

**Note:** Consult your manuals for both the Kingdome Satellite and your new receiver, whether it's Direct TV or Dish Network.

**Before using:** The Satellite may have to be reprogrammed before use, follow instructions in manual.

### **IN MOTION:**

- 1. Make sure AC power is on in the coach**
- 2. Turn TV to channel 3, Bose systems use the TV button – Sony systems use the TV input Zone 2 Bose use the AUX button**
- 3. Turn on Direct TV receiver**
- 4. Turn on Satellite Panel by pushing the on-off button once.**
- 5. If it is necessary to change the region for the satellite (normal due to shipping) push the main button, Panel will say User setup.**
- 6. Push the arrow key next to the main key 1 time. Panel will read Set Region, select the desired region of the USA.**
- 7. Push the arrow key 1 time, checking to see that the next panel says DTV 101.**
- 8. Push the Enter button to finish programming**
- 9. Satellite will automatically locate and lock on to the satellite: follow the directions on the TV to finish.**

## KINGDOM SATELLITE SYSTEM

**Note: Consult your manuals for both the Kingdome Satellite and your new receiver, whether it's Direct TV or Dish Network.**

**Before using: The Satellite may have to be reprogrammed before use. Follow instructions in manual.**

### **AUTOMATIC (non-tracking)**

- 1. Make sure the unit has AC power**
- 2. Turn TV to channel 3, Bose systems use the TV button, Sony systems use the TV input, 2 Bose use the Aux button.**
- 3. Turn on Direct TV receiver**
- 4. Turn on Satellite by pushing the power button (left side) and holding it on for 4 seconds. The blinking light will flash green – then red - release the button**
- 5. If equipped with the D-11 direct TV box (silver) the rest of the setup is automatic – follow the directions on the TV screen.**

**If equipped with the SD\_HBH direct TV box (black), you must manually change the satellite by continuing to push the Power button (on left) for 1 second, until the desired satellite is found. Please read the manual in your warranty box.**

## **MANUAL RETRACTION ON EQUALIZER BED SLIDES**

- 1. Open bed top and remove floor access panel.**
- 2. Remove the 4 screws on the end of the drive motor and pull back approximately  $\frac{3}{4}$  inches. This will disengage the brake function of the motor.**
- 3. Use supplied ratchet & 5/8" socket to manually crank in room.**

## BACK UP CAMERA

**Pioneer Supertuner 3 w/flip out screen & AAV– no side cams**  
To reprogram camera after a complete shutdown.

1. Turn on ignition key
  2. Push Nav/AR button on screen (set of 3 buttons)
  3. Touch blue screen in middle, this will bring up a button on the screen labeled A. menu
  4. Touch A. menu button
  5. Touch setup button
  6. Touch camera button
  7. Confirm camera button stays on, if not, touch camera button 1 time to enable.  
It will say camera polarity  
On battery
  8. Rear camera is re-programmed
- 

**Pioneer Super tuner 3 w/flip out screen & nav with side cams**  
Follow above steps to reprogram camera

1. The switch a=on dash labeled B/U cam will cycle through the 3 cameras determining which one stays on the screen.
2. Putting the unit in reverse will cause the picture to go full screen
3. Turn signals override all other settings. Picture will return to rear view when turn signals are disengaged.

**Super tuner 3 w/flip out screen – no nav.** Same directions as the above, but to bring up the set up button you must use the menu button on the bottom right corner of the stereo.

1. System with back up only – 1 switch on dash to enable full time back-up picture.
2. System with back-up & side view: 2 switches on dash – 1 to enable full time backup picture: 1 to cycle the cameras.

## Operating instructions for Ultra Slide Rooms

- **After moving into the camp site:**
  1. Deploy the leveling system fully and confirm that the coach is level. This may require a small amount of adjustment to the individual leveling jacks.
  2. After the coach is level, deploy the slide rooms.
- **Retracting the slide rooms and moving out of the camp site:**
  1. Fully re-tract all of the slide rooms.
  2. Allow the chassis air suspension system to fully inflate
  3. Raise all of the leveling jacks and confirm that they are in the store mode.
  4. After the chassis air suspension has been fully inflated you are ready to move your unit.

### **Note:**

It is important due to the close tolerances of your slide rooms that your coach is level before deploying your slide rooms and that your air suspension is fully inflated before moving your Motor Home.

## 2012 Audio Video Instructions for XL Models

**Front TV- Turn on Surround System and select TV as sound source. Use the TV remote to select inputs.**

**HDMI- 1- Blue-Ray**

**HDMI- 2- Satellite box (if equipped)**

**TV for Air channels and Park Cable- The Audio will automatically play on all inputs.**

**Bedroom TV- Turn on Bose Wave Radio and select AUX for input. Use the TV remote to select inputs.**

**HDMI- 1- Blue-Ray**

**HDMI- 2- Satellite box (if equipped)**

**TV for Air channels and Park Cable- The Audio will automatically play on all inputs.**

**Outside TV (390 XL) with Soundbar and Radio- Turn on Soundbar and select input. #2 for TV, #3 for stereo. Use the TV remote to select inputs.**

**HDMI- 1- Blue-Ray**

**HDMI- 2- Satellite box (if equipped)**

**The Audio will automatically play on all inputs.**

### Kenwood DDX 318 -no Nav.

Initial setup screen:

- Make sure Rear Camera interrupt is on. Push finish.
- On Top Menu (nav-disk-tuner) is displayed. At the bottom of screen, push setup.
- Scroll down to system, setup memory. Push enter to memorize setup, push yes, memory, yes.
- Exit back to Menu.

Camera use: Automatically comes on in reverse, to use while in motion.

- Push option switch on dash (on-off). This enables camera full time.

### Kenwood 7160- with Nav.

Initial setup screen:

- Go to Camera setup. Make sure R-cam interruption is on. Exit with back button.
  - Scroll to system. Setup memory: unlock: yes: memory: yes again. Exit using Menu button.
  - Select desired function using touch screen.
- Note: You can scroll through the options by touching screen and moving left or right.
- Use Nav by touching the Nav button on stereo face, or scrolling down to Nav in the Menu.
- Note: Option switch on dash enables full time Rear Camera.

## Front LED TV's and Sony Blue-Ray

### **Air channel and Satellite:**

**-Use TV input on Sony.**

**-HDMI input labeled B.D. on Television. Input menu is for Blue-Ray viewing. Audio will automatically switch with disk.**

### **Rear LED TV without Blue-Ray:**

**If not equipped with the optional Sony S-Air module, rear Blue-Ray viewing is not possible. All audio comes from the TV.**

### **Rear LED TV with Blue-Ray:**

**When equipped with the S-Air module, this system can supply the audio from every source available to the main head unit by changing the S-Air channels, either on the face of the S-Air module, or with the supplied remote. To use the Audio channels or satellite, push button on top right corner of S-Air module labeled Audio in.**



## DDX 318- no Nav

**Camera setup:**

**Push Menu. Setup: input: R-cam interrupt –on: Back to system: Setup memory: yes: memory: yes: Completed.**

**Option switch #1 on dash permanently enables camera.  
Option switch #2 cycles through the cameras if equipped with side view cameras.**

## Kenwood 7160 with Nav

### **Initial Camera setup:**

- Turn on the Unit by holding finger over the SRC label. This Unit is entirely touch screen.
  - Push Menu, scroll through the interface until you see the SRC setup button.
  - Tap the screen, touch AV-in button. Make sure the AV-in interruption is on.
  - Scroll down with the bar on the left, touch Camera setup, the rear cam interruption button is the only one that should be on.
  - Go back into the Menu. Scroll up to System, tap, go down to setup memory, tap, push unlock –yes –memory –yes
  - The radio is now programmed for camera.
  - Touch Menu. Scroll down to desired function.
- 
- Option switch #1 on dash (next to clock) permanently enables rearview camera.
  - Option switch #2 cycle through all cameras if equipped with side views.

### Samsung LED TV's and AV.

**-Make sure Ant. booster is on, either the power button on switchbox above stereo or small brown plate on wall above stereo. Green light will show when powered.**

**-Scan for Air channels using TV menu. Channel scan function.**

**-Audio for Air channels is on either the TV or Audio setting on Sony Home Theater.**

**-Blue-Ray function is on the HDMI / DVI input on TV. Use the Source button on remote to select the inputs.**

### Rear TV

**-If equipped, the S-Air module for rear TV will play any sound source from the front stereo. Choose source on the S-Air channel input.**

**-For TV Air channel audio, you must push the audio in button on the top right corner of S-Air module.**

## LP Function

After filling the tank with the LP, enable the main LP valve by turning on the switch above the LP fill. The LP detector inside the coach controls the second valve. If gas is present, the sensor will shut off LP supply. With LP in and all switches in the on position, proceed to light appliances. It is recommended to bleed out the air in the lines by using the gas range first. If you have an electric range, use the furnace first.

## Girard Awnings

Use the remote or wall switch to extend or retreat Awning. The supplied anemometer will automatically bring the Awning in in high winds as long as there is AC power present.

## FSW 3000 Xantrax Inv Charger

Push exit button on right hand side of panel (located in tower behind drivers seat) until desired function is available on bottom of screen. Eninv is enable inverter, pushing this button will enable the inverter to use your 12V battery banks to create 110 volt AC power for the entire coach, except for the air conditioners.

### Dash functions

Regeneration switch (next to lock switch) see visor and Freightliner Manual for more information.

Switch labeled start is an auxiliary start switch. It engages both sets of batteries in case of a problem.

## **SONY SURROUND SOUND**

### **I-POD FUNCTION**

#### **Push start – Living Room**

- **I-Pod – Turn on surround with the RED power button**
- **Push function until USB appears on the face of the surround sound system**
- **Use arrow keys on remote to navigate I-Pod menus on the TV screen**
- **When at the desired song or play list push SELECT Button and adjust volume**

## All Chinese Trucks

**Must install appropriate 240 volt plug end for shore cord.**

**When plugged into shore power, all American appliances are supplied 110 volt power via a step-down transformer.**

**A step-up transformer then supplies 240 volt power to all white receptors.**

**Same applies when on generator.**

**DYNAMAX** A DIVISION OF FOREST RIVER INC  
2745 NORTHLAND DR.  
ELKHART, IN 46514

**CUSTOMER SERVICE**  
(888) 295-7859  
(574) 262-1436 FAX  
[www.dynamaxcorp.com](http://www.dynamaxcorp.com)

**DYNAMAX WEB SITE**  
[www.dynamaxcorp.com](http://www.dynamaxcorp.com)