

LUXURY CROSS-OVERS BY HEARTLAND

DSI
Annual RVDA DEALER
SATISFACTION INDEX
AWARD WINNER



Visit HEARTLAND on:



LUXURY CROSS-OVERS BY HEARTLAND

DSI
Annual RVDA DEALER
SATISFACTION INDEX
AWARD WINNER



Visit HEARTLAND on:





Model TQ 380



Model TQ 290

Cross-Over Vehicles by Heartland

Versatile Fifth Wheel and Travel Trailer Toy Haulers

TORQUE by Heartland combines all the best that traditional RVing has to offer with the versatility of a toy hauler. TORQUE offers fifth wheel and travel trailer floor plans, each providing the ultimate in interior spaciousness and cargo possibilities. Elegant furnishings including designer furniture, matching window treatments on huge picture windows, built-in entertainment centers, quality-crafted cabinets and residential solid surface counter tops provide a unique touch you might not expect in a toy hauler. Join the hundreds of Torque owners that have chosen TORQUE for a truly versatile toy hauler with a luxurious residential look and feel of a traditional fifth wheel or travel trailer.



Model TQ 380



Model TQ 290

Cross-Over Vehicles by Heartland

Versatile Fifth Wheel and Travel Trailer Toy Haulers

TORQUE by Heartland combines all the best that traditional RVing has to offer with the versatility of a toy hauler. TORQUE offers fifth wheel and travel trailer floor plans, each providing the ultimate in interior spaciousness and cargo possibilities. Elegant furnishings including designer furniture, matching window treatments on huge picture windows, built-in entertainment centers, quality-crafted cabinets and residential solid surface counter tops provide a unique touch you might not expect in a toy hauler. Join the hundreds of Torque owners that have chosen TORQUE for a truly versatile toy hauler with a luxurious residential look and feel of a traditional fifth wheel or travel trailer.



Model TQ 290



Model TQ 290



Model TQ 380



Model TQ 380



Model TQ 290



Model TQ 290



Model TQ 380



Model TQ 380

VERSATILE GARAGE SPACE



Model TQ 270HG

VERSATILE GARAGE SPACE



Model TQ 270HG

HG - HIDDEN GARAGE TECHNOLOGY

Model TQ 270HG

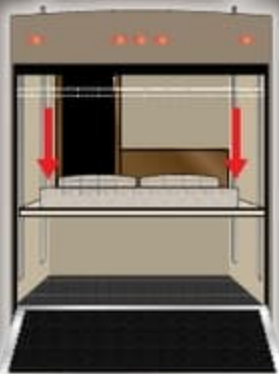

Model TQ 270HG



Light your task, set the mood or just kick back and relax. Enjoy perfect lighting throughout the TORQUE.

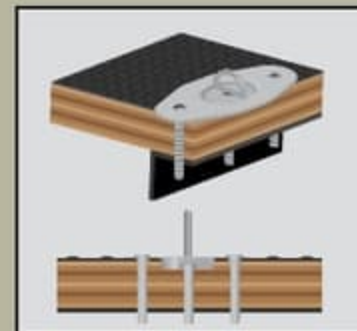

D-Rings

Anchored through the floor decking to the steel frame for maximum strength.



30 GALLONS of FUEL ON THE GO

TORQUE owners Enjoy Safely Transporting Fuel in a Fuel Cell rather than having several 5 gallon fuel cans that take up floor space and can spill if not secured properly. A convenient filling hose and valve handle like you would find at the gas station for filling your toys and the Static Line (Metallic cable and clip that connects the toy and trailer together) that reduces the risk of static electricity sparks that are known to cause explosions!



HG - HIDDEN GARAGE TECHNOLOGY

Model TQ 270HG

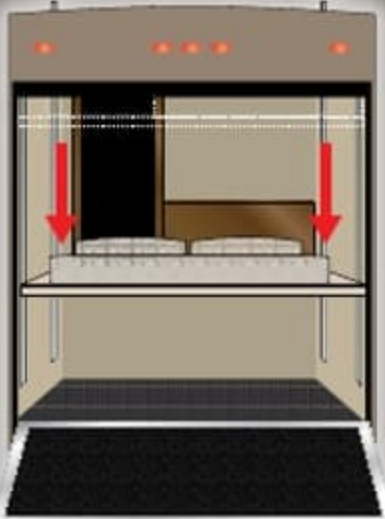

Model TQ 270HG



Light your task, set the mood or just kick back and relax. Enjoy perfect lighting throughout the TORQUE.

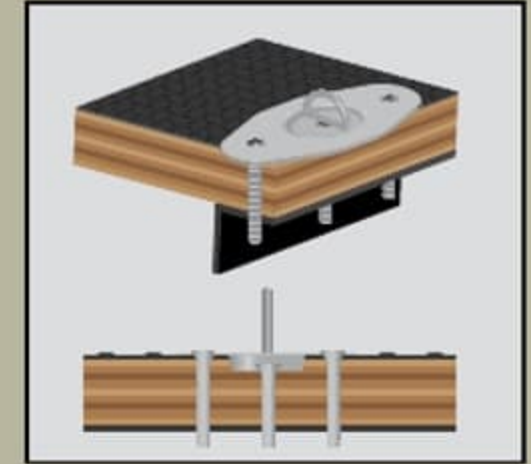

D-Rings
Anchored through the floor decking to the steel frame for maximum strength.



30 GALLONS OF FUEL ON THE GO

TORQUE owners Enjoy Safely Transporting Fuel in a Fuel Cell rather than having several 5 gallon fuel cans that take up floor space and can spill if not secured properly. A convenient filling hose and valve handle like you would find at the gas station for filling your toys and the Static Line (Metallic cable and clip that connects the toy and trailer together) that reduces the risk of static electricity sparks that are known to cause explosions!



10' GARAGE

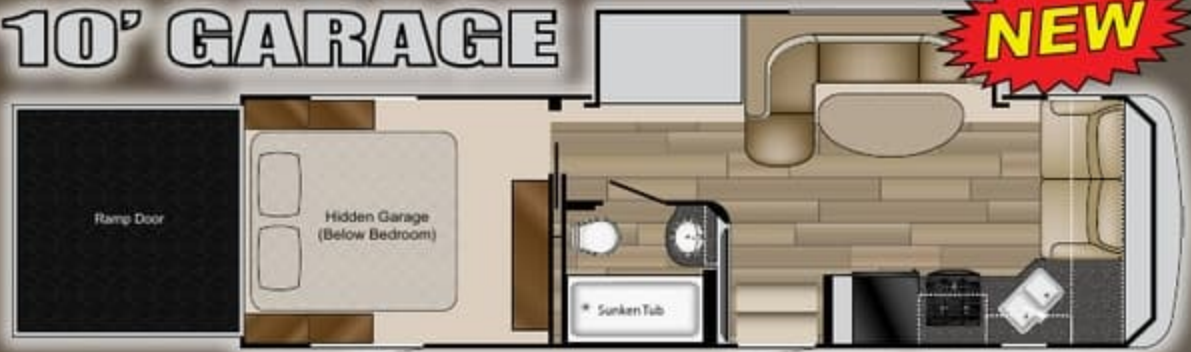

NEW

Patent Pending

TQ 270HG

12' GARAGE



TQ 321

Length: 38' 10" Height: 12' 8" GVWR: 14,000

10' GARAGE



TQ 291

Length: 36' 0" Height: 12' 8" GVWR: 14,000

10' GARAGE



TQ 325

Length: 38' 7" Height: 12' 8" GVWR: 14,000

10' GARAGE



TQ 301

Length: 36' 10" Height: 12' 8" GVWR: 14,000

12' GARAGE



NEW

TQ 380

12' GARAGE



TQ 312

Length: 38' 0" Height: 12' 8" GVWR: 14,000

10' GARAGE



TRAVEL

TQ 261

Length: 34' 5" Height: 12' 0" GVWR: 10,500

10' GARAGE

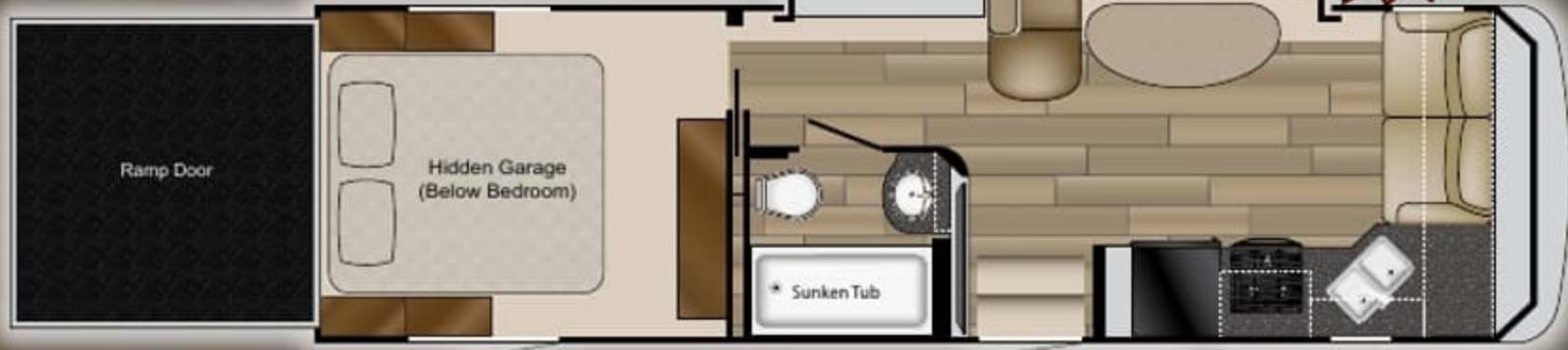

NEW

TQ 270HG

Patent Pending

12' GARAGE



TQ 321

Length: 38' 10" Height: 12' 8" GVWR: 14,000

10' GARAGE



TQ 291

Length: 36' 0" Height: 12' 8" GVWR: 14,000

10' GARAGE



TQ 325

Length: 38' 7" Height: 12' 8" GVWR: 14,000

10' GARAGE



TQ 301

Length: 36' 10" Height: 12' 8" GVWR: 14,000

12' GARAGE



NEW

TQ 380

12' GARAGE



TQ 312

Length: 38' 0" Height: 12' 8" GVWR: 14,000

10' GARAGE



TRAVEL

TQ 261

Length: 34' 5" Height: 12' 0" GVWR: 10,500

HIGHER STANDARDS TORQUE

Interior

- LED Lighting Throughout
- Lauren Ashley Furniture with Built in Recliners
- 3 Interior Décor Choices
- High End Bordeaux Cabinetry
- High End Boxed Lambrequins w/ Mini Blinds
- Pleated Night Shades
- Beauflor Flooring Throughout Unit
- High End Carpeting
- Cable / Satellite Prepped
- DVD/CD/ MP3/ AM/ FM Player
- Dual Ducted 15,000 BTU A/C
- Fire Extinguisher
- LP Detector
- Smoke Detector
- Sliding Glass Door (N/A 270 and 280)
- TT Tanks: Fresh 86 gal, Gray 35 gal, Black 35 gal
- FW Tanks: Fresh 100 gal, Gray 75 gal, Black 41 gal

Exterior

- Correct Track Alignment System (FW only)
- 10" I-Beam Frame Rails (FW) (12" on TQ380)
- 8" I-Beam Frame Rails (TT)
- 16" Steel Wheels (on FW) 15" Steel Wheels (on TT)
- Deep Dark Tinted Windows
- Electric Front Landing Gear (Power Front Jack on TT)
- Fiberglass Front Cap
- Massive Pass Through Storage
- Electric Awning
- 30AMP Service
- Heated and Enclosed Underbelly
- Door Side Porch Light
- Dual High Output Rear Cargo Lights

- Exterior Shower
- High Strength Radius Rubber Roof
- 2" Welded Tubular Aluminum Side Walls
- All New High End Torque Graphics
- High Strength Plastic Grab Handle
- 55 Amp Converter
- 101" Wide Body Design
- Enclosed Goose Neck (FW only)
- Dual 30LBS LP Bottles (Dual 20lbs on TT)
- Wide-Trac Suspension (TT only)
- Rear Manual Stab Jacks
- Aluminum Alloy Wheels

Garage

- Fuel / Oil Resistant Diamond Plate TPO Rubberized Flooring
- Huge Overhead Storage in the Garage
- Diamond Plate Wall Corner Protection
- High Capacity Ramp Door (3,000 lbs.)
- High Efficiency 12V Fan
- Heat and A/C Ducted
- Huge Windows with Blinds
- 24" Beaver Tail

Kitchen

- Solid Surface Countertop in Kitchen Area
- Steel Ball Bearing Drawer Guides - Full Extension
- High Rise Kitchen Pull-Out Faucet
- 3 Burner Range w/ Large Convectional Oven
- Microwave Oven
- Double Door Refrigerator
- Deep Basin Acrylic Sink
- Power Range Hood w/ Light

Bed and Bath

- Single Level Master Suite
- Spacious Sunken Bathtub
- Bath Room Power Vent
- Heat and A/C in Bathroom
- Bedroom TV Hookup with Booster
- Skylight Over Shower
- Over Head Reading Lights
- Hardwood Medicine Cabinet
- 60" X 80" Queen Bed w/ Hi-End Pillow Top Mattress and Comforter

OPTIONS

- Ivory Wood Decor
- 3500 Watt Portable Gen
- Rear Electric Queen Bed w/ Convertible Sofa
- 32" LCD Flat Screen TV
- Vinyl Rear Screen
- Fuel Station w/ Gen Prep (30gal)
- 4000 Watt Onan Built in Generator (Requires Gen Prep w/ Fuel Stat)
- 50 Amp Service (FW only)
- Second A/C (Requires 50 Amp Service)
- 5.5Watt Oman Generator (Requires 50 amp Service) (FW only)
- Fantastic Fan w/ Rain Sensor (Kitchen)
- 32" Bedroom TV

SS PACKAGE

- Painted Front Cap
- Colored Fiberglass Sidewalls
- Exclusive SS Graphics



TRAILERS

12'-17' GARAGE



Length: 35' 3"

Height: 12' 0"

GVWR: 10,500

TQ 280

10' GARAGE



Length: 36' 5"

Height: 12' 0"

GVWR: 13,000

TQ 290

HIGHER STANDARDS TORQUE

Interior

- LED Lighting Throughout
- Lauren Ashley Furniture with Built in Recliners
- 3 Interior Décor Choices
- High End Bordeaux Cabinetry
- High End Boxed Lambrequins' w/ Mini Blinds
- Pleated Night Shades
- Beauflor Flooring Throughout Unit
- High End Carpeting
- Cable / Satellite Prepped
- DVD/CD/ MP3/ AM/ FM Player
- Dual Ducted 15,000 BTU A/C
- Fire Extinguisher
- LP Detector
- Smoke Detector
- Sliding Glass Door (N/A 270 and 280)
- TT Tanks: Fresh 86 gal, Gray 35 gal, Black 35 gal
- FW Tanks: Fresh 100 gal, Gray 75 gal, Black 41 gal

Exterior

- Correct Track Alignment System (FW only)
- 10" I-Beam Frame Rails (FW) (12" on TQ380)
- 8" I-Beam Frame Rails (TT)
- 16" Steel Wheels (on FW) 15" Steel Wheels (on TT)
- Deep Dark Tinted Windows
- Electric Front Landing Gear (Power Front Jack on TT)
- Fiberglass Front Cap
- Massive Pass Through Storage
- Electric Awning
- 30AMP Service
- Heated and Enclosed Underbelly
- Door Side Porch Light
- Dual High Output Rear Cargo Lights

- Exterior Shower
- High Strength Radius Rubber Roof
- 2" Welded Tubular Aluminum Side Walls
- All New High End Torque Graphics
- High Strength Plastic Grab Handle
- 55 Amp Converter
- 101" Wide Body Design
- Enclosed Goose Neck (FW only)
- Dual 30LBS LP Bottles (Dual 20lbs on TT)
- Wide-Trac Suspension (TT only)
- Rear Manual Stab Jacks
- Aluminum Alloy Wheels

Garage

- Fuel / Oil Resistant Diamond Plate TPO Rubberized Flooring
- Huge Overhead Storage in the Garage
- Diamond Plate Wall Corner Protection
- High Capacity Ramp Door (3,000 lbs.)
- High Efficiency 12V Fan
- Heat and A/C Ducted
- Huge Windows with Blinds
- 24" Beaver Tail

Kitchen

- Solid Surface Countertop in Kitchen Area
- Steel Ball Bearing Drawer Guides - Full Extension
- High Rise Kitchen Pull-Out Faucet
- 3 Burner Range w/ Large Convectional Oven
- Microwave Oven
- Double Door Refrigerator
- Deep Basin Acrylic Sink
- Power Range Hood w/ Light

Bed and Bath

- Single Level Master Suite
- Spacious Sunken Bathtub
- Bath Room Power Vent
- Heat and A/C in Bathroom
- Bedroom TV Hookup with Booster
- Skylight Over Shower
- Over Head Reading Lights
- Hardwood Medicine Cabinet
- 60" X 80" Queen Bed w/ Hi-End Pillow Top Mattress and Comforter

OPTIONS

- Ivory Wood Decor
- 3500 Watt Portable Gen
- Rear Electric Queen Bed w/ Convertible Sofa
- 32" LCD Flat Screen TV
- Vinyl Rear Screen
- Fuel Station w/ Gen Prep (30gal)
- 4000 Watt Onan Built in Generator (Requires Gen Prep w/ Fuel Stat)
- 50 Amp Service (FW only)
- Second A/C (Requires 50 Amp Service)
- 5.5Watt Oman Generator (Requires 50 amp Service) (FW only)
- Fantastic Fan w/ Rain Sensor (Kitchen)
- 32" Bedroom TV

SS PACKAGE

- Painted Front Cap
- Colored Fiberglass Sidewalls
- Exclusive SS Graphics



TRAILERS

12'-17' GARAGE



Length: 35' 3"

Height: 12' 0"

GVWR: 10,500

TQ 280

10' GARAGE

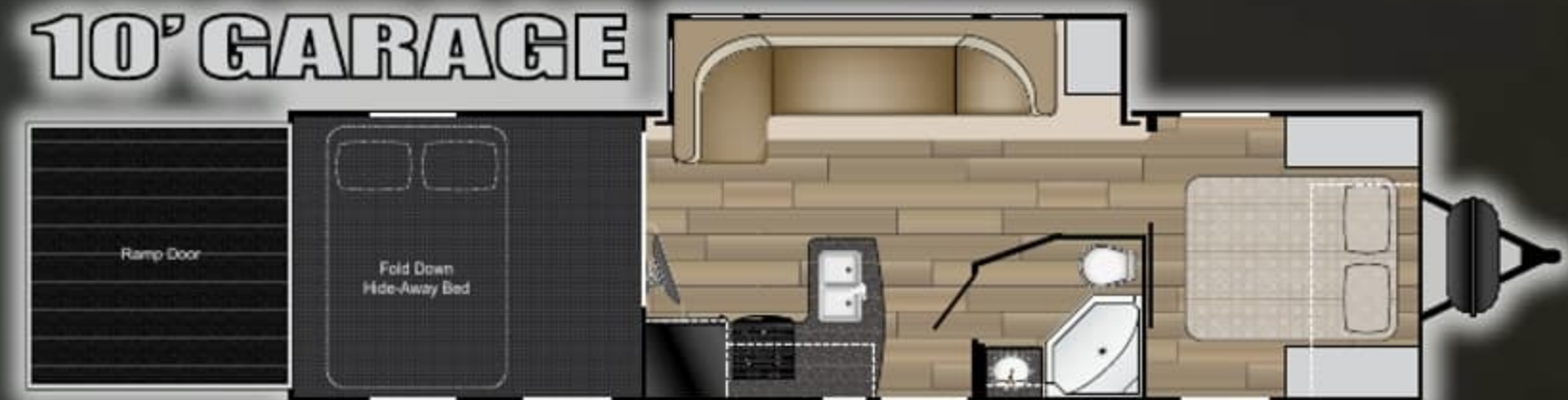

Length: 36' 5"

Height: 12' 0"

GVWR: 13,000

TQ 290



Heartland Recreational Vehicles

1001 All-Pro Drive • Elkhart, IN 46514 • 574-262-5992

Community. Convenience. Close-to-home.

Where you purchase your recreational vehicle is ultimately your decision but Heartland urges you to consider buying at your local dealer. Dealers are part of your community, providing jobs and contributing to your local economy. These dealers are under obligation to provide warranty service for products they sell, but are not legally required to service products purchased from other dealers. At some point, you may need to return to the dealer you buy from - why not stay close to home? After all, home is where your Heartland is!

BENEFITS OF PURCHASING YOUR RV LOCALLY:

- You enjoy valuable relationship building with Dealer Representatives, close to your home, who will explain the features and benefits of the product.
- You receive a full product orientation prior to delivery, which includes hands-on directions for many of the coach's systems and functions. You are also introduced to the Dealership's Service/Parts/Warranty personnel who are at the ready to help you with any issues you may encounter, now and in the future.
- You enjoy customer PRIORITY. Dealerships generally service their purchasing customers first - others may experience long delays and miss opportunities to use their RV. What is it worth for you to have a dealership's full attention and motivation to satisfy you when you need service - in a timely manner?
- Valuable TAX dollars and jobs stay in YOUR community which pays for your roads, schools, police and fire departments.

DON'T UNDERESTIMATE CUSTOMER SERVICE AND PERSONAL CARE!

For Canadian Residents: If you purchase an RV out-of-country, there are additional fees, taxes and inspections that must be met before bringing your product home. Your local Canadian dealers are experts in these provisions.

Visit HEARTLAND on:



Your Authorized Heartland Dealer:

HEARTLAND PROUDLY PARTNERS WITH THE HIGHEST QUALITY VENDORS in manufacturing our recreational vehicles:



HEARTLAND CUSTOMER SERVICE WE'VE GOT YOUR BACK!

Over 40 men and women located in a dedicated facility servicing our customers every day. With a dealer network of over 400 locations across the U.S. and Canada, you're never far from an authorized Heartland dealer.

www.HEARTLANDRVs.com



Experience:

- Product Walk-Through Videos
- Side By Side Comparisons
- Feature Videos • Photo Galleries
- Virtual 360° Tours
- Detailed Floor Plans
- News • Testimonials
- Dealer Locator • Owners Club
- Customer Service • Service Locator
- and More at our Informative Web Site



Product information is as accurate as possible as of the date of publication of this brochure. Due to Heartland's commitment to continuous product improvement - floorplans, materials, components, features, specifications, options, etc. are subject to change without notice or obligation to Heartland Recreational Vehicles.

Product information and specifications apply to coaches beginning with serial number 280295

Tow Vehicle Caution: Owners of Heartland recreational vehicles are solely responsible for the selection and proper use of tow vehicles. All customers should consult with a motor vehicle manufacturer or their dealer concerning the purchase and use of suitable tow vehicles for Heartland products. Heartland disclaims any liability or damages suffered as a result of the selection, operation, use or misuse of a tow vehicle. Heartland's limited warranty does not cover damage to the recreational vehicle or the tow vehicle as a result of the selection of the tow vehicle.

See your nearest Heartland dealer to review a current model.



Heartland Recreational Vehicles

1001 All-Pro Drive • Elkhart, IN 46514 • 574-262-5992

Community. Convenience. Close-to-home.

Where you purchase your recreational vehicle is ultimately your decision but Heartland urges you to consider buying at your local dealer. Dealers are part of your community, providing jobs and contributing to your local economy. These dealers are under obligation to provide warranty service for products they sell, but are not legally required to service products purchased from other dealers. At some point, you may need to return to the dealer you buy from - why not stay close to home? After all, home is where your Heartland is!

BENEFITS OF PURCHASING YOUR RV LOCALLY:

- You enjoy valuable relationship building with Dealer Representatives, close to your home, who will explain the features and benefits of the product.
- You receive a full product orientation prior to delivery, which includes hands-on directions for many of the coach's systems and functions. You are also introduced to the Dealership's Service/Parts/Warranty personnel who are at the ready to help you with any issues you may encounter, now and in the future.
- You enjoy customer PRIORITY. Dealerships generally service their purchasing customers first - others may experience long delays and miss opportunities to use their RV. What is it worth for you to have a dealership's full attention and motivation to satisfy you when you need service - in a timely manner?
- Valuable TAX dollars and jobs stay in YOUR community which pays for your roads, schools, police and fire departments.

DON'T UNDERESTIMATE CUSTOMER SERVICE AND PERSONAL CARE!

For Canadian Residents: If you purchase an RV out-of-country, there are additional fees, taxes and inspections that must be met before bringing your product home. Your local Canadian dealers are experts in these provisions.

Visit HEARTLAND on:



Your Authorized Heartland Dealer:

HEARTLAND PROUDLY PARTNERS WITH THE HIGHEST QUALITY VENDORS in manufacturing our recreational vehicles:



HEARTLAND CUSTOMER SERVICE WE'VE GOT YOUR BACK!

Over 40 men and women located in a dedicated facility servicing our customers every day. With a dealer network of over 400 locations across the U.S. and Canada, you're never far from an authorized Heartland dealer.

www.HEARTLANDRVs.com



Experience:

- Product Walk-Through Videos
- Side By Side Comparisons
- Feature Videos • Photo Galleries
- Virtual 360° Tours
- Detailed Floor Plans
- News • Testimonials
- Dealer Locator • Owners Club
- Customer Service • Service Locator
- and More at our Informative Web Site



Product information is as accurate as possible as of the date of publication of this brochure. Due to Heartlands commitment to continuous product improvement - floorplans, materials, components, features, specifications, options, etc. are subject to change without notice or obligation to Heartland Recreational Vehicles. Product information and specifications apply to coaches beginning with serial number 280295

Tow Vehicle Caution: Owners of Heartland recreational vehicles are solely responsible for the selection and proper use of tow vehicles. All customers should consult with a motor vehicle manufacturer or their dealer concerning the purchase and use of suitable tow vehicles for Heartland products. Heartland disclaims any liability or damages suffered as a result of the selection, operation, use or misuse of a tow vehicle. Heartland's limited warranty does not cover damage to the recreational vehicle or the tow vehicle as a result of the selection of the tow vehicle. See your nearest Heartland dealer to review a current model.